

HOW TO HOT-WIRE A CAR

Hot-wiring a car without the owner's permission is illegal, except in repossessions. Hot-wiring can be dangerous; there is a risk of electrical shock. Hot-wiring will not work on all cars, particularly cars with security devices. Some "kill switches" can prevent hot-wiring.

1 Open the hood.

2 Locate the coil wire (it is red).

To find it, follow the plug wires, which lead to the coil wire. The plug and coil wires are located at the rear of the engine on most V-8s. On six-cylinder engines, the wires are on the left side near the center of the engine, and on four-cylinder engines, they are located on the right side near the center of the engine.

3 Run a wire from the positive (+) side of the battery to the positive side of the coil, or the red wire that goes to the coil.

This step gives power to the dash, and the car will not run unless it is performed first.

4 Locate the starter solenoid.

On most GM cars, it is on the starter. On Fords, it is located on the left-side (passenger-side) fender well.

Run a wire from the positive (+) side of the battery to the red coil wire.

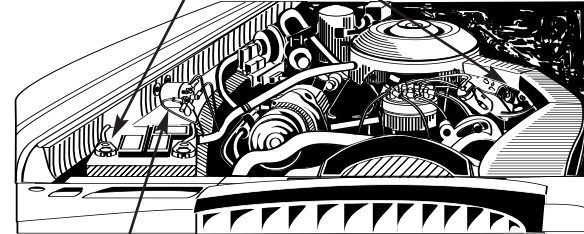

solenoid

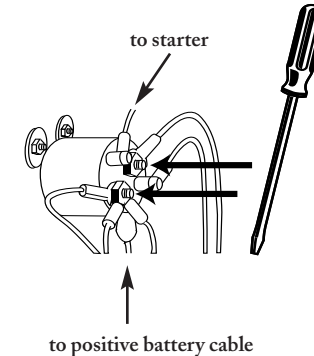

Cross the terminals with a screwdriver or pliers (Ford).

An easy way to find it is to follow the positive battery cable. You will see a small wire and the positive battery cable. Cross the two with a screwdriver or pliers. This cranks the engine.

Unlocking the Steering Wheel

*Place screwdriver
at top center of
steering column.*

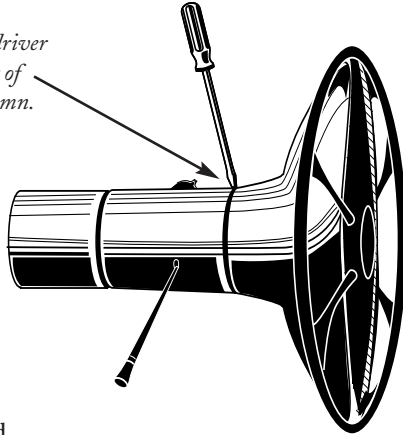

GM solenoid

- 5** If the car has a standard transmission, make sure it is in neutral and the parking brake is on. If it has an automatic transmission, make sure it is in park.

- 6** Unlock the steering wheel using a flat blade screwdriver. Take the screwdriver and place it at the top center of the steering column. Push the screwdriver between the steering wheel and the column. Push the locking pin away from the wheel. Be very firm when pushing the pin; it will not break.

**WORST-CASE
SCENARIO.**